

Co-occurrence Features of Multi-scale Directional Filter Bank for Texture Characterization

K. O. Cheng, N. F. Law, and W. C. Siu

Centre for Multimedia Signal Processing
Department of Electronic & Information Engineering
The Hong Kong Polytechnic University
Hong Kong

Abstract—In this paper, we propose to use co-occurrence features computed from multi-scale directional filter bank (MDFB) for texture characterization. As the filter band coefficients are localized frequency components, features from co-occurrence matrices of filter bands can characterize structures of textures by describing correlation among coefficients. Our experiments show that the co-occurrence features outperform energy features considerably in texture retrieval. In particular, they significantly improve the retrieval rate for textures with weak directionality and periodicity while still maintain a high retrieval rate for regular textures as the energy features.

I. INTRODUCTION

Due to advanced multimedia technology, the growth of storage and distribution of images in digital form increases rapidly. To facilitate searching and access of image content from a large database such as digital libraries, content-based image retrieval (CBIR) has been introduced. Compared with text-based approach, CBIR does not require manual annotation for each image and is not limited by availability of lexicons. In CBIR, texture has widely been used as an image feature together with colour and shape, for example, homogenous texture descriptor in MPEG-7 [1]. Therefore, an effective and efficient extraction of texture features is much desired.

Many techniques of feature extraction have been developed for textures. Among them, multi-channel filtering approaches have received much attention in recent years. One of the main principles behind them is that human visual system perceives image in a scale and orientation manner [2]. Gabor filters [3] and multi-scale directional filter bank (MDFB) [4] are two of multi-channel approaches which can decompose an image into scale and directional components in a feasible way. For textures, the energy signature such as L1 norm or L2 norm of each filter band is usually computed as features. On the other hand, Wouwer *et al.* [5] have shown that co-occurrence features extracted in wavelet domain can improve texture characterization considerably. Using wavelets, an image is decomposed into localized frequency

components. Spatial correlation of wavelet coefficients due to the structure of textures can be captured by the co-occurrence features. In this paper, we propose to use co-occurrence features calculated from MDFB for texture description. The components of MDFB are also localized but with higher angular frequency resolution than wavelet. We describe and explain the co-occurrence matrices computed from MDFB subbands for feature extraction. Experimental results in texture retrieval are provided to show the effectiveness of the proposed features for texture characterization.

This paper is organized as follows. In Section II, the MDFB adopted is introduced. Then, computation of proposed co-occurrence features from MDFB is discussed in Section III. The experimental results of the proposed features in texture retrieval and comparative studies are given in Section IV. Finally, we conclude this paper in Section V.

II. MULTI-SCALE DIRECTIONAL FILTER BANK

A multi-scale directional filter bank (MDFB) proposed in [4] is used to decompose a texture image into various scale and direction components. The block diagram of MDFB is illustrated in Fig. 1. First, an image is split into a lowpass and a highpass images using a lowpass filter $h_0[\mathbf{n}]$ with passband $[0, 3\pi/4]$. The lowpass image is further decomposed into two bandpass images using Laplacian pyramid with the prototype filter $h_L[\mathbf{n}]$. The three bandpass images, which correspond to frequency bands $[\pi/4, \pi/2]$, $[\pi/2, 3\pi/4]$ and $[3\pi/4, \pi]$, are considered for texture characterization whereas the lowest resolution image is ignored. No feature is extracted from the lowest resolution image because characteristics of textures mainly appear in high and mid frequency ranges. For each of the three bandpass images, DFB with non-modulated structure [6] is applied to obtain directional components in the corresponding scale. In the following content, the multi-scale and multi-directional decomposition is denoted by (l_1, l_2, l_3) , where l_s denotes the decomposition level of DFB at scale s . The subband at scale s in direction d is denoted by $x_{s,d}$.

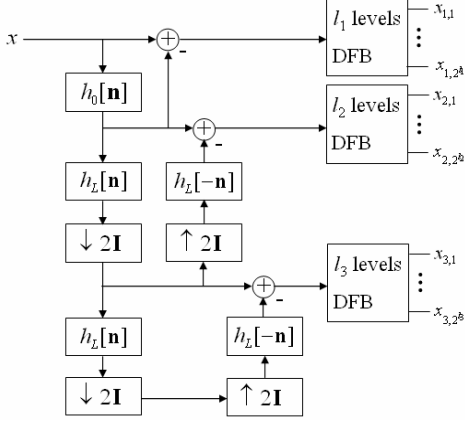

Figure 1. Block diagram of MDFB.

III. THE PROPOSED CO-OCCURRENCE FEATURES

Co-occurrence matrices can describe the statistics of pixel values (or coefficients) at two positions with a fixed displacement in an image (or a subband). Features computed from co-occurrence matrices can thus characterize the spatial relation between pixels (or subband coefficients) and are widely studied in texture characterization [5, 7]. In this section, we describe how we obtain features from co-occurrence matrices in subbands of MDFB.

A. Co-occurrence Matrices

Denote the intensity function of an image and the co-occurrence matrix at distance δ in direction θ as $I(x, y)$ and $C^{\delta, \theta}$ respectively. The (i, j) entry of the matrix $C^{\delta, \theta}$ represents the relative frequency of co-occurrence of an intensity value equal to i and its neighboring intensity value at distance δ in direction θ equal to j . Mathematically, before normalized by total number of pairs, it is given by

$$C^{\delta, \theta}(i, j) = \# \{ (x_1, y_1), (x_2, y_2) \in (L_x \times L_y) \times (L_x \times L_y) : I(x_1, y_1) = i, I(x_2, y_2) = j, \text{ where } x_1 - x_2 = \delta \cos \theta \text{ and } y_1 - y_2 = \delta \sin \theta \text{ or } x_1 - x_2 = -\delta \cos \theta \text{ and } y_1 - y_2 = -\delta \sin \theta \}$$

where L_x and L_y are horizontal and vertical domains of the image respectively. Hence, co-occurrence matrices of various distances and directions can characterize the geometric features in an image. Equation (1) can be used to compute the co-occurrence matrices in filter bands. However, filter bands usually consist of coefficients in real numbers rather than integers so quantization is required to first convert the coefficients into discrete values, i.e.,

$$q(x_{s,d}) = \text{round}[x_{s,d} / Q]$$

where Q is the quantization step size to be determined experimentally.

B. Proposed Co-occurrence Features For MDFB

In DFB, the decimations in horizontal and vertical directions are not the same. Specifically, for an $N \times N$ image with l levels decomposition, the subbands either have size of $N/2^{l-1} \times N/2$ or $N/2 \times N/2^{l-1}$ after decimation. More information can be found in the direction of smaller downsampling factor, i.e. higher resolution. Therefore, co-occurrence matrix of distance one in either vertical or horizontal direction is computed for each subband in MDFB. The direction with smaller downsampling factor is selected. The co-occurrence matrix is of distance one only because significant correlation between coefficients exists only in small displacement in textures [5].

From each co-occurrence matrix, eight types of co-occurrence features proposed in [5] are calculated and analyzed for texture retrieval. Since all of them together would introduce a high dimensional feature vector, combinations of features up to two different types are investigated only. The combination which gives the highest retrieval rate in experiment should be selected as the texture features. In addition, it is possible to combine the co-occurrence features with energy signatures such as L1 norm and L2 norm given as Ek , $k = 1, 2$ in (3) respectively for texture characterization. The retrieval performance of different combinations is studied in Section IV in detail.

$$Ek = \left(\frac{1}{N_i N_j} \sum_{i=1}^{N_i} \sum_{j=1}^{N_j} |x_{s,d}[i, j]|^k \right)^{1/k}$$

where $k = 1, 2$ and $N_i \times N_j$ is the size of the subband.

IV. EXPERIMENTAL RESULTS

The retrieval performance of the proposed co-occurrence features from MDFB is studied using a texture database derived from 111 512x512 texture images in Brodatz album. Each album image is split into 16 128x128 non-overlapping sub-images. Sub-images from the same album image are regarded to be of the same class. This results in a database of 1776 images with 111 classes. Each image in the database is used as a query image one by one in the experiment. Before feature extraction, histogram equalization is performed to reduce the bias of intensity distribution towards sub-images from the same album image. The similarity between two texture images, image 1 and image 2, is defined as weighted Euclidean distance between their feature vectors [3], i.e.,

$$D(\mathbf{f}^{(1)}, \mathbf{f}^{(2)}) = \left(\sum_{i=1}^N (f_i^{(1)} - f_i^{(2)})^2 / \sigma_i^2 \right)^{1/2}$$

where $\mathbf{f}^{(k)}$ is the feature vector of texture image k , $f_i^{(k)}$ is the i -th element of $\mathbf{f}^{(k)}$ and σ_i is the standard deviation of the i -th element of the feature vectors in the entire database.

MDFB of decomposition (3, 4, 3) is used. The filters in DFB are implemented using the ladder structure of finite impulse response [8]. The half-band lowpass filter used in Laplacian pyramid is a binomial filter of length 15. It has been shown that this specification of MDFB gives a relatively high retrieval rate compared with others for energy signatures [4]. In order to optimize the quantization step size Q for subband coefficients mentioned in Section III.A, the experiment is performed several times with different values of Q . It is found that the retrieval rate converges to a maximum around $Q=4$ for all the co-occurrence features. Hence, we set $Q=4$ throughout the experiment.

A. Comparison with energy signatures

The overall average retrieval rate of combined features up to two different types, which include co-occurrence features as well as energy signatures, is summarized in Table I. The average retrieval rates using energy signatures E1 and E2 are 67.2% and 67.4% over the entire database respectively. However, with the use of co-occurrence features C3 and C8, the average retrieval rate increases to 72.3%, which is the highest among all the combinations. Also, combined with C8, the average retrieval rates of E1 and E2 are increased by 4.5% and 4.4% respectively.

The use of co-occurrence features actually improves retrieval performance by increasing the complexity in feature extraction. As the computation of co-occurrence matrices can be realized by bit-shifting (for quantization), additions and indexing, we can assume that the computational complexity of co-occurrence matrices is similar to that of energy features. The extra computations are hence due to features calculation from co-occurrence matrices. However, feature extraction for database images is usually performed offline so the retrieval time would only be increased in a very little amount.

B. Comparison with co-occurrence features from DWT

Comparative study has been performed with the co-occurrence features extracted from 4 levels D-spline discrete wavelet transform (DWT) of order 2. In the DWT algorithm,

greedy algorithm has been applied to select the co-occurrence feature types for retrieval. It was found that five different feature types gave the best performance. This resulted in 60 features for each texture image. The results are summarized in Table II. It can be seen that the best result for co-occurrence features from MDFB as shown in Table I is 5.4% higher than that from the DWT while the number of features required is kept about the same. The improvement is due to the higher angular resolution provided by DFB.

C. Further analysis

In order to further study the co-occurrence features, the average retrieval rate for each texture class, which is provided in Table III, is examined. It is found that the retrieval rate is improved for most of the texture classes. The improvement is significant for texture classes D002, D005, D067 and D074. As can be seen in Fig.2, all of them lack of directionality and periodicity. This implies that co-occurrence features of MDFB can characterize regular textures at various scales and orientations whereas still account for the randomness of irregular textures. This is due to the fact that the co-occurrence features provide a statistical texture description, which complement the spectral texture description in the MDFB.

V. CONCLUSION

Co-occurrence features for multi-scale directional filter bank have been proposed for texture characterization. The co-occurrence features can describe the spatial correlation of subband coefficients. Thus, the geometrical arrangement of texture features in various scale and direction can be characterized. Experiments show that the use of co-occurrence features results in higher retrieval performance than the energy features especially for the irregular textures. Furthermore, the MDFB is superior than DWT for co-occurrence features extraction. As a result, the proposed features provide both a statistical and a spectral texture description which effectively describe the structural features for both regular and irregular textures.

TABLE I. RETRIEVAL RATE (%) FOR DIFFERENT COMBINATIONS UP TO TWO TYPES OF CO-OCCURRENCE FEATURES AND/OR ENERGY FEATURES.^{A,B}

Feature		Co-occurrence features ^c								Energy signature	
		C1	C2	C3	C4	C5	C6	C7	C8	E1	E2
Co-occurrence feature	C1	63.1	64.9	67.1	66.5	65.2	57.3	61.7	69.7	66.4	66.4
	C2	-	59.2	66.6	64.9	58.7	46.4	59.6	69.3	67.1	67.7
	C3	-	-	67.5	67.1	66.5	60.2	65.2	72.3	67.8	68.3
	C4	-	-	-	65.2	64.5	58.1	64.5	71.6	67.5	68.4
	C5	-	-	-	-	57.9	49.1	60.7	69.8	67.0	67.9
	C6	-	-	-	-	-	30.5	47.3	60.2	61.1	61.1
	C7	-	-	-	-	-	-	51.4	65.9	64.2	63.9
	C8	-	-	-	-	-	-	-	65.7	71.7	71.8
Energy signature	E1	-	-	-	-	-	-	-	-	67.2	67.6
	E2	-	-	-	-	-	-	-	-	-	67.4

a. Due to symmetry of the table, only half of retrieval rate is shown.

b. The use of combination of features of the same type is equivalent to the use of features of that type without combination.

c. Co-occurrence features C1-C8 refer to inertia, total energy, entropy, local homogeneity, max. probability, cluster shade, cluster prominence and information measure of correlation respectively.

TABLE II. COMPARISON OF RETRIEVAL RESULTS

	Best proposed features	Co-occurrence features from DWT
Retrieval rates (%)	72.3	66.9
No. of features	64	60

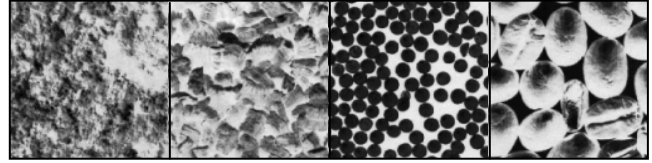

Figure 2. Samples for classes D002, D005, D067 and D074 (left to right).

TABLE III. AVERAGE RETRIEVAL RATE (%) FOR EACH TEXTURE CLASSES WITH DIFFERENT FEATURES.

Class	Features				Class	Features				Class	Features			
	E1	E2	E2,C8	C3,C8		E1	E2	E2,C8	C3,C8		E1	E2	E2,C8	C3,C8
D001	92	93	95	95	D002	59	60	66	95	D003	46	48	58	64
D004	100	100	100	99	D005	79	76	77	99	D006	100	100	100	100
D007	34	35	45	45	D008	91	90	99	45	D009	56	54	60	61
D010	73	73	77	76	D011	100	100	100	76	D012	82	83	80	82
D013	40	39	40	42	D015	48	47	46	42	D016	100	100	100	100
D017	100	100	100	100	D018	96	97	96	100	D019	84	84	94	97
D020	100	100	100	100	D021	100	100	100	100	D022	48	49	52	66
D023	43	45	60	59	D024	89	88	89	59	D025	48	54	56	55
D026	84	88	93	91	D027	41	41	54	91	D028	64	64	68	71
D029	100	100	100	98	D030	46	41	44	98	D031	40	37	52	56
D032	63	64	74	79	D033	75	82	88	79	D034	99	100	100	99
D035	57	58	61	64	D036	41	42	46	64	D037	93	97	99	98
D038	64	66	71	73	D039	42	42	54	73	D040	48	43	56	61
D041	63	63	83	89	D042	34	35	41	89	D043	25	23	25	26
D044	23	22	25	29	D045	21	18	23	29	D046	97	97	88	88
D047	95	99	98	96	D048	95	93	90	96	D049	100	100	100	100
D050	65	59	70	65	D051	79	73	73	65	D052	100	100	100	100
D053	100	100	100	100	D054	49	54	59	100	D055	100	100	100	100
D056	100	100	99	99	D057	100	100	100	99	D058	17	18	22	22
D059	21	18	32	30	D060	39	38	43	30	D061	38	33	40	39
D062	38	39	40	40	D063	21	24	33	40	D064	98	98	100	100
D065	100	100	100	100	D066	77	74	91	100	D067	39	42	61	60
D068	98	100	100	99	D069	24	25	30	99	D070	75	76	81	78
D071	25	25	29	32	D072	38	38	38	32	D073	46	50	60	59
D074	63	58	90	92	D075	80	84	93	92	D076	99	97	100	100
D077	100	100	100	100	D078	100	100	100	100	D079	98	98	100	100
D080	100	100	100	100	D081	100	100	100	100	D082	100	100	100	100
D083	100	100	100	100	D084	100	100	100	100	D085	98	99	100	100
D086	81	81	85	85	D087	86	87	91	85	D088	50	50	65	66
D089	39	39	52	53	D090	29	26	31	53	D091	30	29	29	30
D092	80	79	79	79	D093	85	88	88	79	D094	70	79	91	89
D095	100	100	100	100	D096	69	76	85	100	D097	23	22	21	23
D098	51	52	66	70	D099	27	23	30	70	D100	44	46	62	54
D101	89	88	79	73	D102	93	93	87	73	D103	56	56	52	53
D104	48	48	54	55	D105	65	65	71	55	D106	55	54	50	49
D107	25	25	30	31	D108	37	36	46	31	D109	40	41	44	43
D110	50	50	59	64	D111	41	43	58	64	D112	54	51	56	57

ACKNOWLEDGMENT

This work is supported by RGC Grant PolyU 5222/03E and the Centre for Multimedia Signal Processing (A452), the Hong Kong Polytechnic University.

REFERENCES

[1] T. Sikora, "The MPEG-7 visual standard for content description – an overview," IEEE Trans. Circuits Syst. Video Technol., vol. 11, pp. 696-702, June 2001.

[2] J. G. Daugman, "Uncertainty relation for resolution in space, spatial frequency, and orientation optimized by two-dimensional visual cortical filters," J. Opt. Soc. Am. A, vol. 2, pp. 1160-1169, July 1985.

[3] B. S. Manjunath and W. Y. Ma, "Texture features for browsing and retrieval of image data," IEEE Trans. Pattern Anal. Machine Intell., vol. 18, pp. 837-842, August 1996.

[4] W. Y. Chan, N. F. Law, and W. C. Siu, "Multiscale feature analysis using directional filter bank," ICICS-PCM'03, vol.2, pp.822-826, Dec 2003.

[5] G. V. D. Wouwer, P. Scheunders, and D. V. Dyck, "Statistical texture characterization from discrete wavelet representations," IEEE Trans. Image Processing, vol. 8, pp. 592-598, April 1999.

[6] S.-I. Park, M. J. T. Smith, and R. M. Mersereau, "A new directional filter bank for image analysis and classification," ICASSP'99, vol. 3, pp. 1417-1420, March 1999.

[7] A. Busch, W. W. Boles and S. Sridharan, "Logarithmic quantisation of wavelet coefficients for improved texture classification performance," ICASSP'04, vol. 3, pp. III-569-572, May 2004.

[8] S.-M. Phoong, C. W. Kim, P. P. Vaidyanathan, and R. Ansari, "A new class of two-channel biorthogonal filter banks and wavelet bases," IEEE Trans. Signal Processing, vol. 43, no. 3, pp. 649-665, March 1995.